

IJTECH 2018

by Ardiaty Arief

Submission date: 26-Sep-2022 03:09AM (UTC-0400)

Submission ID: 1909233907

File name: EECE-913_Analytical-Method-for-Reactive-Power-Compensators-.pdf (487.32K)

Word count: 4501

Character count: 24162

ANALYTICAL METHOD FOR REACTIVE POWER COMPENSATORS ALLOCATION

Ardiaty Arief^{1,2*}, Muhammad Bachtiar Nappu^{1,2}, Antamil³

¹Centre for Research and Development on Energy and Electricity, Hasanuddin University, Jl. Perintis Kemerdekaan Km. 10 Tamalanrea, Makassar 90245, Indonesia

²Power and Energy Systems Research Group, Department of Electrical Engineering, Faculty of Engineering, Hasanuddin University, Jl. Poros Malino Km. 6, Bontomarannu, Gowa 92172, Indonesia

³Faculty of Science and Technology, Department of Information Technology, Alauddin Islamic State University, Jl. H.M. Yasin Limpo No. 36, Gowa 92113, Indonesia

10

(Received: November 2017 / Revised: January 2018 / Accepted: February 2018)

ABSTRACT

This paper presents a novel analytical methodology to determine the placement of reactive power devices in power systems. The proposed method modifies the Modal analysis technique and, based on the inversed reduced Jacobian matrix, develops a new formulation to compute the Reactive Contribution Factor (RCF) of each load buses. The objective of this research is to achieve the most stable condition and to minimize network losses. The proposed method is implemented at the modified IEEE 30-bus Reliability Test System (RTS) and compared with a different placement. In order to assess the method, this work compares the voltage profile, eigenvalue and network losses. The simulation results show that the proposed method can provide a solution to the ideal shunt compensator placement by improving the system's voltage stability and by minimizing losses.

Keywords: Eigenvalue; Losses reduction; Modal analysis; Reactive power compensator placement; Voltage stability

1. INTRODUCTION

For almost one century, system stability has been viewed as an important requirement for a power system to operate safely and reliably operation in (Dong & Zhang, 2009). Nowadays, modern power systems are severely stressed and work at the stability limit with smaller capacity and margin. Hence, these may cause congestion problems (Nappu et al., 2013; Nappu et al., 2014; Nappu & Arief 2016). The progressive and uncontrollable drop in voltage as a result of increase in load demand and, more especially, due to reactive loads or changes in system operation conditions, can result eventually in a widespread voltage collapse (Prada et al., 2015). Therefore, protective steps, such as load shedding, may be taken (Arief et al., 2013). In order to avoid this instability, there are several preventive steps that can be taken; one of them is the installation of a reactive power compensation scheme. This compensation device in the power system provides reactive power compensation; reduces network losses; reduces energy losses; improves the voltage profile; releases system capacity; and recovers the power factor (Sajjadi et al., 2013; Taher & Bagherpour, 2013; Arief et al., 2016).

*Corresponding author's email: ardiaty@eng.unhas.ac.id, Tel: +62-812-4169-3305, Fax: +62-411-587-032
Permalink/DOI: <https://doi.org/10.14716/ijtech.v9i3.913>

In placing reactive power compensation devices, there are three issues that become major concerns; these are: namely, size of compensation; number; and location of placement (Kavousi-Fard & Niknam, 2013; Lee et al., 2015). Furthermore, with high penetration of renewable energy generations into power systems and, more especially, wind power plants, this has created more challenges in reactive power compensating planning (Xu et al., 2017). Hence, the daily maintenance, reliability and security of the system's operation has become more difficult due to wind resources intermittency (Zhang et al., 2016; Zhang et al., 2017). This is especially so since countries worldwide have targeted the expansion of renewable energy resources for the electricity industry. For example, Australia targeted that 20% of their power generation supply would be provided by renewable energy by 2020 (Radzi et al., 2012).

There are various reactive compensation devices such as capacitors, SVC or STATCOM. In recent years, various methodologies have been developed for placement of these devices. In general, the reactive compensator placement can be categorized into analytical methods, heuristic methods, numerical methods and methods based on Artificial Intelligence (AI) (Aman et al., 2014). With regard to the analytical methods, the computation procedures are reduced by making some approximations. Cook (1959) developed a well-known analytical method for capacitor placement when he proposed that the optimum capacitor placement ought to be 2/3 of the reactive load factor. However, in certain cases, the application of this "2/3 rule" may give negative financial savings (Lee & Grainger, 1981). Heuristic methods are practical methods that are developed by using researchers' intuitions and experiences which provide a satisfactory solution. Hamouda & Sayah (2013) and Raju et al. (2012) applied the heuristic method in relation to reactive power compensators placements. Numerical programming is an iterative technique that uses arithmetic mathematical formulations to maximize or minimize or an objective function of decision variables which fulfil, also, a set of constraints. Nojavan et al. (2014) presented an integer nonlinear programming approach. Aguiar & Cuervo's (2005) work formulated a mixed integer linear programming that considered the discrete capacitor sizes. However, its rationality rested on the precision of the loss formula estimation. Various AI approaches have been implemented in the placement of capacitors. For example, Ramadan et al. (2014) developed a fuzzy logic based approach which combined two membership functions and Abul'Wafa (2014) combined fuzzy expert system for the placement of the capacitor and read coded Genetic Algorithm (GA) to calculate the size of the capacitor. Nonetheless, in using fuzzy logic, the main challenge is to determine accurately the fuzzy membership functions and the fuzzy rule bases. In their papers, Lee et al. (2015) and Zeinalzadeh et al. (2015) implemented the Particle Swarm Optimization (PSO) approach was. Nevertheless, the reliance of the PSO algorithm on the altering factors and the trapping in modifying parameters' probability can reduce its accuracy and efficacy for various conditions. Other researches about reactive power placement, which employed AI procedures, are Bacterial Foraging Optimization Algorithm (BFOA) (Devabalaji et al., 2015), artificial bee colony algorithm (El-Fergany & Abdelaziz, 2014), search space of A (Carpinelli et al., 2010), hybrid method of CODEQ (HCODEQ) (Chiou & Chang, 2015), teaching learning based optimization (Sultana & Roy, 2014), Gravitational Search Algorithm (GSA) (Shuaib et al., 2015), Clustering Based Optimization (CBO) (Vuletić & Todorovski, 2014) and bio-inspired optimization (Duque et al., 2015). The applications of AI in solving capacitor placement may have effectual operation and can handle complicated problems. However, they are more difficult to code and, potentially, can provide volatile outcomes in early stage convergence. Although AI methods have been validated on the sample systems, nevertheless, the success of these methods relies on the modification of algorithmic considerations whose optimal setting involves users' skill and knowledge (Jabr, 2008). Therefore, where this information can be obtained from the Jacobian matrix of the system, it is important to develop an effective method that is able to provide information about voltage stability within the system.

This study developed a new analytical method to improve Modal analysis for the effective placement of reactive power compensation devices. Modal analysis is an analytic solutions approach that can describe the condition of voltage stability in a complex network (Gao et al., 1992). Using the modal analysis method, the inversed reduced Jacobian matrix is computed and informs the relationship between change in the voltage and the change in reactive power injection at each buses. By utilizing the relationship of V and Q, this approach can identify weak points and areas that are vulnerable to system stability. The relationship between voltage (V) and reactive power (Q) can be used to obtain useful information about stability. This work offers a simple algorithm and it is simple to implement the method. The advantages of this approach are that it is fast, straight, accurate and does not involve composite computational processes. The novelty of this research is the modification of Modal Analysis method and, then, the formulation of the Reactive Contribution Factor (RCF) that is obtained from the inversed reduced Jacobian matrix. RCF gives information about a specific bus' contribution to improving voltage magnitude at critical buses.

2. METHODOLOGY

2.1. Elaboration of Modal Analysis Computation of Reduced Jacobian Matrix

In order to perform modal analysis, linearized steady-state power voltage equations are used as follows:

$$\begin{bmatrix} \Delta P \\ \Delta Q \end{bmatrix} = \begin{bmatrix} J_{P\theta} & J_{PV} \\ J_{Q\theta} & J_{QV} \end{bmatrix} \begin{bmatrix} \Delta\theta \\ \Delta V \end{bmatrix} \quad (1)$$

where, ΔP is the incremental change in bus real power; ΔQ is the incremental change in bus reactive power injection; $\Delta\theta$ is the incremental change in bus voltage angle; and ΔV is the incremental change in bus voltage magnitude

In order to assess the relationship of voltage and reactive power stability, the active power (P) is kept constant. Due to constant active power ($\Delta P = 0$), then, Equation 1 can be reduced to:

$$\begin{bmatrix} 0 \\ \Delta Q \end{bmatrix} = \begin{bmatrix} J_{P\theta} & J_{PV} \\ J_{Q\theta} & J_{QV} \end{bmatrix} \begin{bmatrix} \Delta\theta \\ \Delta V \end{bmatrix}$$

$$0 = J_{P\theta} \Delta\theta + J_{PV} \Delta V$$

$$\Delta\theta = -J_{PV} \Delta V + J_{P\theta}^{-1} \quad (2)$$

$$\Delta Q = J_{Q\theta} \Delta\theta + J_{QV} \Delta V \quad (3)$$

If Equation 2 is substituted into the Equation 3, then:

$$\Delta Q = [J_{QV} - J_{Q\theta} J_{P\theta}^{-1} J_{P\theta}] \Delta V \quad (4)$$

$$J_R = [J_{QV} - J_{Q\theta} J_{P\theta}^{-1} J_{P\theta}]$$

$$\Delta Q = J_R \Delta V$$

$$\Delta V = J_R^{-1} \Delta Q \quad (5)$$

J_R^{-1} or inversed reduced Jacobian matrix is a matrix that shows a direct correlation between the bus voltage and the reactive power injection. This assumes that the active power is zero and the voltage angle is substituted and, then, that, obtained from the equation, is much simpler and more focused.

2.2. Computation of Reactive Contribution Factor (RCF)

From Equation 5, it can be seen that the voltage change (ΔV) is obtained by multiplying the reactive power injection at specific buses with the inversed reduced Jacobian matrix (J_R^{-1}). When the J_R^{-1} is further elaborated, then:

$$\begin{bmatrix} \Delta V_1 \\ \Delta V_2 \\ \vdots \\ \Delta V_m \end{bmatrix} = \begin{bmatrix} \mathfrak{R}_{11} & \mathfrak{R}_{12} & \dots & \mathfrak{R}_{1n} \\ \mathfrak{R}_{21} & \mathfrak{R}_{22} & \dots & \mathfrak{R}_{2n} \\ \vdots & \vdots & \ddots & \vdots \\ \mathfrak{R}_{m1} & \mathfrak{R}_{m2} & \dots & \mathfrak{R}_{mn} \end{bmatrix} \begin{bmatrix} \Delta Q_1 \\ \Delta Q_2 \\ \vdots \\ \Delta Q_m \end{bmatrix} \quad (6)$$

$$J_R^{-1} = \begin{bmatrix} \mathfrak{R}_{11} & \mathfrak{R}_{12} & \dots & \mathfrak{R}_{1n} \\ \mathfrak{R}_{21} & \mathfrak{R}_{22} & \dots & \mathfrak{R}_{2n} \\ \vdots & \vdots & \ddots & \vdots \\ \mathfrak{R}_{m1} & \mathfrak{R}_{m2} & \dots & \mathfrak{R}_{mn} \end{bmatrix}$$

The RCF values at each load buses are computed by adding the elements of inversed reduced Jacobian matrix vertically so that RCF at bus j becomes:

$$RCF_j = \mathfrak{R}_{1j} + \mathfrak{R}_{2j} + \mathfrak{R}_{3j} + \dots + \mathfrak{R}_{mj} \quad (7)$$

$$RCF_j = \sum_{i=1}^n \mathfrak{R}_{ij}$$

where, \mathfrak{R}_{ij} is the i^{th} row and j^{th} is the column element of the inversed reduced Jacobian matrix. RCF informs the contribution of each bus to improving voltage stability. Furthermore, as the aim of compensator placement is to improve voltage stability, the computation of RCF focuses only on the effect to the unstable buses. The RCF is calculated for all buses and in respect to the unstable buses.

2.3. Computation of Eigenvalues as Stability Index

Eigenvalues are obtained from the reduced Jacobian matrix (J_R) which describes the level of stability of the system. Eigenvalues of J_R can be used to identify circumstances when the system becomes voltage unstable. The magnitude of the eigenvalues provides an estimate of relative proximity of the system to instability. For practical purposes, the reduced Jacobian matrix is a symmetric matrix, If V-Q is positive, then, all eigenvalues are positive, also; this indicates that the system is voltage stable. As the system becomes more stressed, the eigenvalues of J_R become smaller at the critical point of the system voltage stability. The eigenvalue of J_R becomes:

$$\text{Eigen } [J_R] = \begin{bmatrix} \lambda_1 & 0 & \dots & 0 \\ 0 & \lambda_2 & \dots & 0 \\ \vdots & \vdots & \ddots & \vdots \\ 0 & 0 & 0 & \lambda_n \end{bmatrix} \quad (8)$$

2.4. Procedure Algorithm of the Proposed Method

The proposed method's step by step procedure can be explained as follow: *Step 1*: perform power flow program to calculate voltage magnitude at all buses and network losses; *Step 2*: identify critical buses and buses with voltage below stability limit 0.95 pu; *Step 3*: perform modified Modal analysis to calculate the RCF from the inversed J_R . The computed RCF is

focuses only on the critical buses. ¹ The location of compensator is chosen based on the highest contribution to improving the voltages at critical buses; this is indicated by the highest RCF. *Step 4:* install reactive power compensation devices with the size of 5 MVar in the buses with the highest RCF; *Step 5:* perform power flow to compute network losses and evaluate the system's voltage stability. The system is considered to be stable if the voltage in all buses is between voltage stability limit $0.95 \leq V \leq 1.05$ pu; *Step 6:* If at least 1 bus has voltage below 0.95 pu, then go ⁷ back to Step 3. If all voltage buses are within the stability limit, then, assess the robustness of the proposed method by comparing the results with different placements.

3. RESULTS AND DISCUSSION

3.1. The Test System: The Modified IEEE 30-bus Reliability ¹⁹ Test System (RTS) ²⁴

In order to conduct a comprehensive test of the above methods, IEEE 30-bus Reliability Test System (RTS) is used. This test system is modified in such a way as to obtain an initial state that allows it to perform testing of the proposed method. Figure 1 shows the test system with new bus numbering.

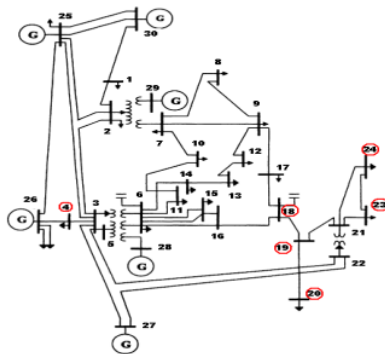

Figure 1 The IEEE 30-bus Reliability Test System (Saadat, 1999)

3.2. Computation of Reactive Contribution Factor ¹²

Figure 2 shows the system voltage profile on the initial conditions. The total active power losses are 23.383 MW, while the reactive power losses are 51.261 MVar. The smallest eigenvalue for this initial condition is 0.4673.

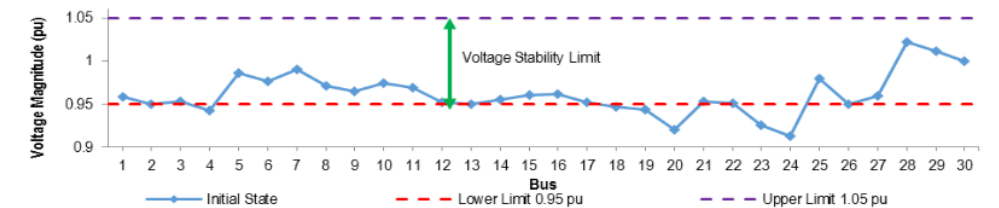

Figure 2 Voltage magnitude at the initial state

As can be seen in Figure 2, there are six critical load buses whose voltages are below 0.95 p.u. voltage ²⁹ stability limit. These are buses 4, 18, 19, 20, 23 and 24 and are indicated with red circles ³³ in Figure 1. Table 1 shows the voltage magnitude for these unstable buses.

In order to determine the correct location for compensator placement for the purpose of covering the shortage of reactive power, the RCF is calculated for all buses so that their impacts

on these critical buses can be observed. Therefore, with 6 unstable buses, the RCF of each load buses is calculated in respect of the critical buses and, hence:

$$RCF_j = \mathfrak{R}_{4,j} + \mathfrak{R}_{18,j} + \mathfrak{R}_{19,j} + \mathfrak{R}_{20,j} + \mathfrak{R}_{23,j} + \mathfrak{R}_{24,j}$$

Table 1 Buses with voltage under stability limit

Bus	Voltage Magnitude (p.u.)	Bus	Voltage Magnitude (p.u.)
4	0.943	20	0.920
18	0.947	23	0.926
19	0.944	24	0.913

For example, to compute RCF³⁷ at bus 1:

$$RCF_1 = \mathfrak{R}_{4,1} + \mathfrak{R}_{18,1} + \mathfrak{R}_{19,1} + \mathfrak{R}_{20,1} + \mathfrak{R}_{23,1} + \mathfrak{R}_{24,1}$$

Table 2 shows the complete calculation of RCF values for the first iteration of all load buses. As indicated with blue font, bus 24 has the highest RCF of 1.9542. Hence, for the first iteration, bus 24 become the best location for capacitor placement.

Table 2 Reactive Contribution Factor (RCF) Computation for the first iteration

Bus	RCF	Bus	RCF	Bus	RCF	Bus	RCF
1	0.0609	7	0.1461	13	0.2830	19	1.3918
2	0.0727	8	0.2079	14	0.2849	20	1.8584
3	0.0867	9	0.2614	15	0.3790	21	1.3197
4	0.1025	10	0.2079	16	0.4055	22	0.2000
5	0.1606	11	0.2660	17	0.4752	23	1.8715
6	0.2881	12	0.2757	18	0.7578	24	1.9542

Figure 3 informs the computation of RCF for all buses. After the first iteration of power flow, with an injection of 5 MVar, the voltage magnitudes of the buses around bus 24 improve. The buses' voltages are close to that of bus 24 such as bus 21's and bus 23's straight increase significantly.

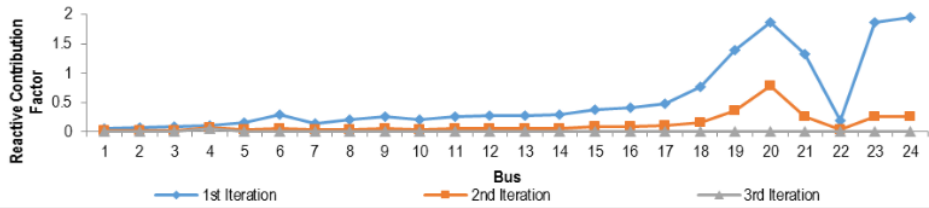

Figure 3 Reactive Contribution Factor (RCF) computation iteration process

However, the voltages of buses 24, 18, 19 and 20 are still below the stability limit 0.95 pu. Then, the reactive compensation injection still needs to be added and the RCF is calculated again to find the next location for the placement of compensator devices. In the second iteration, bus 20's RCF is the highest (Figure 3). With another addition of reactive compensation to bus 20 of 5 MVar, the system is not yet stable and, hence, another process of

calculating RCF is done at the third iteration. This found that bus 4 had the highest RCF. With bus 4's 5 MVar capacitor, the system has recovered its stability and, hence, the process is stopped. Figure 4 shows the voltage profile improvement, recorded for each iteration, after the capacitor's placement at the nominated buses. Table 3 informs the detailed location of the capacitor based on the highest RCF at each iteration.

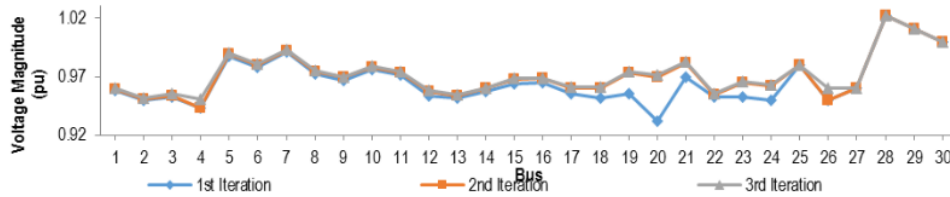

Figure 4 Voltage profile improvement at each iteration

35
Table 3 Location and size of compensator in each iteration

Iteration	Bus	Injected MVar
1	24	5
2	20	5
3	4	5

The total required reactive power compensation is 15 MVar with the assumption that the minimum voltage, achieved on each bus, is injected at 0.95 pu. After the installation of the above mentioned 3 nodes, the system's voltage profile has recovered to its stable condition. Buses that were previously under voltage stability limit are now above 0.95 pu.

Figure 5 illustrates the increase of eigenvalue in each iteration. Eigenvalues increased from 0.4673 to 0.5082. This explains how the stability level improves with the addition of reactive compensations.

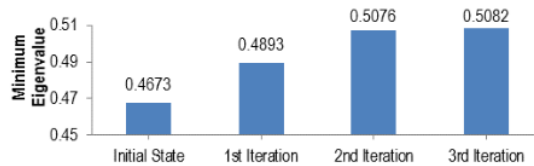

Figure 5 Eigenvalue at each iteration

38
The system's active power losses reduced from 23.383 MW to 23.187 MW. Also, the reactive power reduced from 51.362 MVar to 50.002 MVar. Table 4 shows the complete power losses in each iteration

Table 4 Network losses in each iteration

No	State	Total Losses	
		MW	MVAR
1	Initial State	23.383	51.362
2	1st Iteration	23.274	50.703
3	2nd Iteration	23.191	50.212
4	3rd Iteration	23.187	50.002

3.3. Evaluation of the Proposed Method

In order to assess the robustness of the proposed method, the results of reactive power compensator placement are compared with the placement of a 15 MVar compensator in one single critical/unstable bus. Figure 6 shows the voltage profile after the installation of compensators of a total of 15 MVar reactive power injections in selected buses and based on the proposed method. In this case, the location of the 15 MVar reactive power injection is in the critical buses which are buses 4, 18, 19, 20, 23 or 24. The installation of a 15 MVar reactive power in bus 4 leaves it as unstable as the other buses. There are still 5 buses with voltages below the stability limit, i.e. buses 18, 19, 20, 23, and 24. When bus 18 is selected for the placement of a 15 MVar reactive power compensator, it leaves 4 buses under the stability limit, i.e. buses 4, 20, 23 and 24. If either bus 19 or 20 or 23 or 24 is chosen as the injection site, this still leaves bus 4's voltage below the stability limit of 0.944 pu. On the other hand, if compensators are placed according to the proposed method, all the voltages are stable.

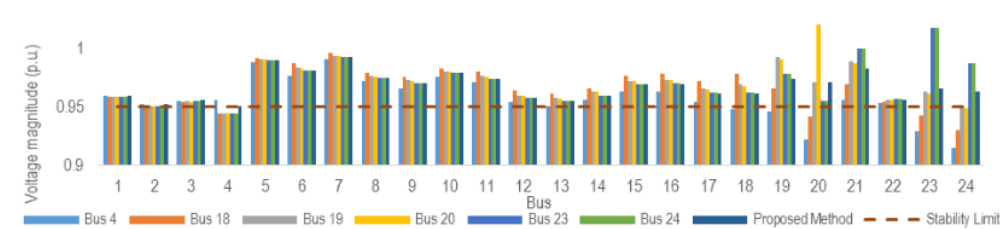

Figure 6 Comparison of voltage magnitude at different placement and proposed method

Figure 7 informs the comparison of network losses if compensators are placed based on the settings in assessment 1 and proposed method. It shows clearly that, if reactive power compensators are placed at buses 24, 20 and 4 with each having 5 MVar, both the active and reactive power losses are the smallest. This means that placing compensators in buses, according to the proposed method, gives the better stable system, better voltage profile and minimum power losses.

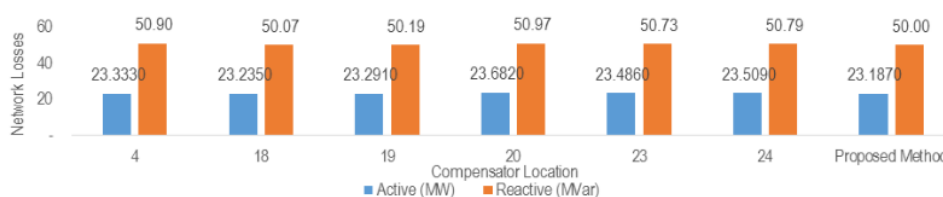

Figure 7 Comparison of network losses

4. CONCLUSION

This paper presents a new method for the placement of reactive power compensation devices by improving the Modal analysis technique by utilizing a direct connection between V & Q in the inversed reduced Jacobian matrix. This paper formulated a new Reactive Contribution Factor (RCF) computed from the elements of the inversed reduced Jacobian matrix. The RCF informs the size of the contribution of a specific bus from improving the voltage magnitude in critical buses. The greater a bus' RCF, the greater that bus' influence in improving the voltage of the critical buses.

The proposed method is tested on the modified IEEE 30-bus Reliability Test System. Based on the proposed method, the total reactive power compensator for the system is 15 MVar. With

this amount, the proposed method was compared then with different compensators of 15 MVar placements. When of after capacitor placement, the system's stability condition and network losses are based on the proposed method are compared to these different placements, the system's overall voltage profile, based on the proposed method, is better than the system's overall voltage profile if 15 MVar is placed in other buses.

5. ACKNOWLEDGEMENT

The authors gratefully thanks the Indonesian Ministry of Research, Technology and Higher Education for providing the research grant and their support in this work.

6. REFERENCES

- Abul'Wafa, A.R., 2014. Optimal Capacitor Placement for Enhancing Voltage Stability in Distribution Systems using Analytical Algorithm and Fuzzy-real Coded GA. *International Journal of Electrical Power & Energy Systems*, Volume 55, pp. 246–252
- Aguiar, R.S., Cuervo, P., 2005. Capacitor Placement in Radial Distribution Networks through a Linear Deterministic Optimization Model. In: 15th Power Systems Computation Conference, Liege, Belgium, August 22–26
- Aman, M.M., Jasmon, G.B., Bakar, A.H.A., Mokhlis, H., Karimi, M., 2014. Optimum Shunt Capacitor Placement in Distribution System—A Review and Comparative Study. *Renewable and Sustainable Energy Reviews*, Volume 30, pp. 429–439
- Arief, A., Antamil, Nappu, M.B., 2016. An Analytical Method for Optimal Capacitors Placement from the Inversed Reduced Jacobian Matrix. *Energy Procedia*, Volume 100, pp. 307–310
- Arief, A., Dong, Z., Nappu, M.B., Gallagher, M., 2013. Under Voltage Load Shedding in Power Systems with Wind Turbine-driven Doubly Fed Induction Generators. *Electric Power Systems Research*, Volume 96, pp. 91–100
- Carpinelli, G., Proto, D., Noce, C., Russo, A., Varilone, P., 2010. Optimal Allocation of Capacitors in Unbalanced Multi-converter Distribution Systems: A Comparison of Some Fast Techniques based on Genetic Algorithms. *Electric Power Systems Research*, Volume 80(6), pp. 642–650
- Chiou, J.-P., Chang, C.-F., 2015. Development of a Novel Algorithm for Optimal Capacitor Placement in Distribution Systems. *International Journal of Electrical Power & Energy Systems*, Volume 73, pp. 684–690
- Cook, R.F., 1959. Analysis of Capacitor Application as Affected by Load Cycle. *Transactions of the American Institute of Electrical Engineers. Part III: Power Apparatus and Systems*, Volume 78(3), pp. 950–956
- Devabalaji, K.R., Ravi, K., Kothari, D.P., 2015. Optimal Location and Sizing of Capacitor Placement in Radial Distribution System using Bacterial Foraging Optimization Algorithm. *International Journal of Electrical Power & Energy Systems*, Volume 71, pp. 383–390
- Dong, Z.Y., Zhang, P., 2009. *Emerging Techniques in Power System Analysis*. Springer
- Duque, F.G., de Oliveira, L.W., de Oliveira, E.J., Marcato, A.L.M., Silva Jr, I.C., 2015. Allocation of Capacitor Banks in Distribution Systems through a Modified Monkey Search Optimization Technique. *International Journal of Electrical Power & Energy Systems*, Volume 73, pp. 420–432
- El-Fergany, A.A., Abdelaziz, A.Y., 2014. Capacitor Placement for Net Saving Maximization and System Stability Enhancement in Distribution Networks using Artificial Bee Colony-based Approach. *International Journal of Electrical Power & Energy Systems*, Volume 54, pp. 235–243

- Gao, B., Morison, G.K., Kundur, P., 1992. Voltage Stability Evaluation using Modal Analysis. *IEEE Transactions on Power Systems*, Volume 7(4), pp. 1529–1542
- Hamouda, A., Sayah, S., 2013. Optimal Capacitors Sizing in Distribution Feeders using Heuristic Search based Node Stability Indices. *International Journal of Electrical Power & Energy Systems*, Volume 46, pp. 56–64
- Jabr, R.A., 2008. Optimal Placement of Capacitors in a Radial Network using Conic and Mixed Integer Linear Programming. *Electric Power Systems Research*, Volume 78(6), pp. 941–948
- Kavousi-Fard, A., Niknam, T., 2013. Considering Uncertainty in the Multi-objective Stochastic Capacitor Allocation Problem using a Novel Self Adaptive Modification Approach. *Electric Power Systems Research*, Volume 103, pp. 16–27
- Lee, C.-S., Ayala, H.V.H., Coelho, L.d.S., 2015. Capacitor Placement of Distribution Systems using Particle Swarm Optimization Approaches. *International Journal of Electrical Power & Energy Systems*, Volume 64, pp. 839–851
- Lee, S.H., Grainger, J.J., 1981. Optimum Placement of Fixed and Switched Capacitors on Primary Distribution Feeders. *IEEE Transaction on Power Apparatus System*, Volume PAS-100(1), pp. 345–352
- Nappu, M.B., Arief, A., Bansal, R.C., 2014. Transmission Management for Congested Power System: A Review of Concepts, Technical Challenges and Development of a New Methodology. *Renewable and Sustainable Energy Reviews*, Volume 38, pp. 572–580
- Nappu, M.B., Arief, A., 2016. Network Losses-based Economic Redispatch for Optimal Energy Pricing in a Congested Power System. *Energy Procedia*, Volume 100, pp. 311–314
- Nappu, M.B., Bansal, R.C., Saha, T.K., 2013. Market Power Implication on Congested Power System: A Case Study of Financial Withheld Strategy. *International Journal of Electrical Power & Energy Systems*, Volume 47, pp. 408–415
- Nojavan, S., Jalali, M., Zare, K., 2014. Optimal Allocation of Capacitors in Radial/Mesh Distribution Systems using Mixed Integer Nonlinear Programming Approach. *Electric Power Systems Research*, Volume 107, pp. 119–124
- Prada, R.B., de Souza, L.J., Lafitte Vega, J., 2015. The Need for Voltage Stability Analysis in Voltage-controlled Buses. *International Journal of Electrical Power & Energy Systems*, Volume 68, pp. 252–258
- Radzi, N.H., Bansal, R.C., Dong, Z.Y., Hasan, K.N., Lu, Z., 2012. Overview of the Australian National Electricity Market Transmission Use of System Charges for Integrating Renewable Generation to Existing Grid. *IET Generation, Transmission & Distribution*, Volume 6, pp. 863–873
- Raju, M.R., Murthy, K.R., Ravindra, K., 2012. Direct Search Algorithm for Capacitive Compensation in Radial Distribution Systems. *International Journal of Electrical Power & Energy Systems*, Volume 42(1), pp. 24–30
- Ramadan, H.A., Wahab, M.A.A., El-Sayed, A.-H.M., Hamada, M.M., 2014. A Fuzzy-based Approach for Optimal Allocation and Sizing of Capacitor Banks. *Electric Power Systems Research*, Volume 106, pp. 232–240
- Saadat, H., 1999. *Power System Analysis*. McGraw-Hill, Boston, U.S
- Sajjadi, S.M., Haghifam, M.-R., Salehi, J., 2013. Simultaneous Placement of Distributed Generation and Capacitors in Distribution Networks Considering Voltage Stability Index. *International Journal of Electrical Power & Energy Systems*, Volume 46, pp. 366–375
- Shuaib, Y.M., Kalavathi, M.S., Rajan, C.C.A., 2015. Optimal Capacitor Placement in Radial Distribution System using Gravitational Search Algorithm. *International Journal of Electrical Power & Energy Systems*, Volume 64, pp. 384–397

- Sultana, S., Roy, P.K., 2014. Optimal Capacitor Placement in Radial Distribution Systems using Teaching Learning based Optimization. *International Journal of Electrical Power & Energy Systems*, Volume 54, pp. 387–398
- Taher, S.A., Bagherpour, R., 2013. A New Approach for Optimal Capacitor Placement and Sizing in Unbalanced Distorted Distribution Systems using Hybrid Honey Bee Colony Algorithm. *International Journal of Electrical Power & Energy Systems*, Volume 49, pp. 430–448
- Vuletić, J., Todorovski, M., 2014. Optimal Capacitor Placement in Radial Distribution Systems using Clustering based Optimization. *International Journal of Electrical Power & Energy Systems*, Volume 62, pp. 229–236
- Xu, Y., Dong, Z.Y., Zhang, R., Hill, D.J., 2017. Multi-Timescale Coordinated Voltage/Var Control of High Renewable-penetrated Distribution Systems. *IEEE Transactions on Power Systems*, Volume 32(6), pp. 4398–4408
- Zeinalzadeh, A., Mohammadi, Y., Moradi, M.H., 2015. Optimal Multi Objective Placement and Sizing of Multiple DGs and Shunt Capacitor Banks Simultaneously Considering Load Uncertainty via MOPSO Approach. *International Journal of Electrical Power & Energy Systems*, Volume 67, pp. 336–349
- Zhang, Y., Dong, Z.Y., Luo, F., Zheng, Y., Meng, K., Wong, K.P., 2016. Optimal Allocation of Battery Energy Storage Systems in Distribution Networks with High Wind Power Penetration. *IET Renewable Power Generation*, Volume 10(8), pp. 1105–1113
- Zhang, Y., Zheng, Y., Meng, K., Dong, Z.Y., 2017. Flexible Operation Planning Scheme Considering Wind Power Generation Forecasting Uncertainties. *Electric Power Components and Systems*, Volume 45(5), pp. 465–475

ORIGINALITY REPORT

17%

SIMILARITY INDEX

8%

INTERNET SOURCES

13%

PUBLICATIONS

4%

STUDENT PAPERS

PRIMARY SOURCES

- | | | |
|---|--|----|
| 1 | Ardiaty Arief, ZhaoYang Dong, Muhammad Bachtiar Nappu, Marcus Gallagher. "Under voltage load shedding in power systems with wind turbine-driven doubly fed induction generators", Electric Power Systems Research, 2013
Publication | 1% |
| 2 | Submitted to Higher Education Commission Pakistan
Student Paper | 1% |
| 3 | Submitted to University of Melbourne
Student Paper | 1% |
| 4 | assets.researchsquare.com
Internet Source | 1% |
| 5 | Abdollah Kavousi-Fard, Taher Niknam. "Considering uncertainty in the multi-objective stochastic capacitor allocation problem using a novel self adaptive modification approach", Electric Power Systems Research, 2013
Publication | 1% |
-

6	M.M. Aman, G.B. Jasmon, A.H.A. Bakar, H. Mokhlis, M. Karimi. "Optimum shunt capacitor placement in distribution system—A review and comparative study", <i>Renewable and Sustainable Energy Reviews</i> , 2014 Publication	1 %
7	iieta.org Internet Source	1 %
8	Chandrabhan Sharma, Marcus G. Ganness. "Determination of the applicability of using modal analysis for the prediction of voltage stability", 2008 IEEE/PES Transmission and Distribution Conference and Exposition, 2008 Publication	<1 %
9	Submitted to School of Business and Management ITB Student Paper	<1 %
10	mjee.org Internet Source	<1 %
11	scholarhub.ui.ac.id Internet Source	<1 %
12	Submitted to 535 Student Paper	<1 %
13	Ana Fernández-Guillamón, Antonio Viguera-Rodríguez, Ángel Molina-García. "Analysis of power system inertia estimation in high wind	<1 %

power plant integration scenarios", IET Renewable Power Generation, 2019

Publication

14

digilib.unhas.ac.id

Internet Source

<1 %

15

K.R. Devabalaji, T. Yuvaraj, K. Ravi. "An efficient method for solving the optimal sitting and sizing problem of capacitor banks based on cuckoo search algorithm", Ain Shams Engineering Journal, 2016

Publication

<1 %

16

www.aimspress.com

Internet Source

<1 %

17

K.A. Ellithy, A. Gastli, T. Al-Khusaibi, M. Irving. "Voltage stability margins assessment for Muscat power system", International Journal of Electrical Power & Energy Systems, 2002

Publication

<1 %

18

repositorio.comillas.edu

Internet Source

<1 %

19

Ming Niu, , and Zhao Yang Dong. "DE-based two-stage reactive power planning with wind power penetration", 9th IET International Conference on Advances in Power System Control Operation and Management (APSCOM 2012), 2012.

Publication

<1 %

20 R.A. Jabr. "Optimal placement of capacitors in a radial network using conic and mixed integer linear programming", Electric Power Systems Research, 2008 <1 %
Publication

21 onlinelibrary.wiley.com <1 %
Internet Source

22 www.scribd.com <1 %
Internet Source

23 Hirlekar, Himanshu S., and Badrul H. Chowdhury. "Towards on-line voltage stability assessment using synchrophasors", 2012 IEEE Power and Energy Society General Meeting, 2012. <1 %
Publication

24 I. Musirin. "EVOLUTIONARY PROGRAMMING BASED OPTIMAL REACTIVE POWER PLANNING FOR VOLTAGE STABILITY IMPROVEMENT AND LOSS MINIMIZATION IN POWER SYSTEM", International Journal of Power and Energy Systems, 2009 <1 %
Publication

25 M. Reza Safari Tirtashi, Olof Samuelsson, Jorgen Svensson. "Dynamic and static analysis of the shunt capacitors control effect on the long-term voltage instability", 2016 IEEE <1 %

Power and Energy Society General Meeting (PESGM), 2016

Publication

26

Submitted to SASTRA University

Student Paper

<1 %

27

Submitted to Universitas Indonesia

Student Paper

<1 %

28

journal.njtd.com.ng

Internet Source

<1 %

29

ocs.uniosun.edu.ng

Internet Source

<1 %

30

tudr.thapar.edu:8080

Internet Source

<1 %

31

www.sid.ir

Internet Source

<1 %

32

About El-Ela, Adel Ali, Mohamed Taha Mouwafi, Abdel-Mohsen Kinawy, and Ragab A. El-Sehiemy. "Optimal capacitor placement in distribution systems for power loss reduction and voltage profile improvement", IET Generation Transmission & Distribution, 2016.

Publication

<1 %

33

Advances in Intelligent Systems and Computing, 2016.

Publication

<1 %

Energy Systems, 2013.

34

Publication

<1 %

35

Moradi Far, Amir, and Asghar Akbari Foroud. "Cost-effective optimal allocation and sizing of active power filters using a new fuzzy-MABICA method", IETE Journal of Research, 2015.

Publication

<1 %

36

S. I. Suliman, T. K. Abdul Rahman. "Artificial immune system based machine learning for voltage stability prediction in power system", 2010 4th International Power Engineering and Optimization Conference (PEOCO), 2010

Publication

<1 %

37

Tarek Medalel Masaud, Geethika Nannapaneni, Rajab Chaloo. "Optimal placement and sizing of distributed generation-based wind energy considering optimal self VAR control", IET Renewable Power Generation, 2017

Publication

<1 %

38

faratarjome.ir

Internet Source

<1 %

39

repository.its.ac.id

Internet Source

<1 %

40

www.ijrrs.com

Internet Source

<1 %

41

www.praiseworthyprize.org

Internet Source

<1 %

42

www.teses.usp.br

Internet Source

<1 %

43

Dexuan Zou, Fei Wang, Nannan Yu, Xiangyong Kong. "Solving many-objective optimisation problems by an improved particle swarm optimisation approach and a normalised penalty method", International Journal of Bio-Inspired Computation, 2019

Publication

<1 %

44

Bishnu Sapkota. "Study of voltage collapse cases of a large power system using static and dynamic approaches", 2009 IEEE/PES Power Systems Conference and Exposition, 03/2009

Publication

<1 %

45

Pankita Mehta, Praghnes Bhatt, Vivek Pandya. "Optimal selection of distributed generating units and its placement for voltage stability enhancement and energy loss minimization", Ain Shams Engineering Journal, 2015

Publication

<1 %

Exclude bibliography On